

For high capacity, fine-grinding of limestone, fertilizers including nitrate, phosphate and potash and other friable materials.

Features/Advantages

Whatever your fine-grinding application, the NANOSIZ-R single-stage roll mill delivers crushing performance that provides a real edge in your day-to-day operations. It's compact, it's affordable and it's perfect for making 1 to 2 mm (.04" to .08") product.

- Bimodal crushing (shear plus compression) of friable materials from 19 mm (.75") feeds to 1600-micron (.06") product.
- High tonnage crushing capability — up to 36.3 metric tons (40 metric tons) per hour.
- Lower capital and energy costs than existing technologies.
- Small footprint compared to other equipment, so fits in small spaces.
- Modular design — multiple units can be used in series to achieve greater reduction ratios.

Versatility

- Coal Industry — built on Gundlach Crusher's innovative and reliable roll mill technology, the NANOSIZ-R is ideal for fine-grinding applications in power plants where fine limestone is required to reduce the sulfur content of emissions.
- Fertilizer Production — The NANOSIZ-R works on many different fertilizers and provides better control of the finished product size range. Whether you're processing nitrate, phosphate or potash ... with flake, agglomerated, hot or dry materials ... there's a NANOSIZ-R well-equipped to get your fine-grinding job done.

Variety of Rugged, Long-Lasting Roll Designs

There are dozens of roll configurations available to meet your specific applications or crushing needs.

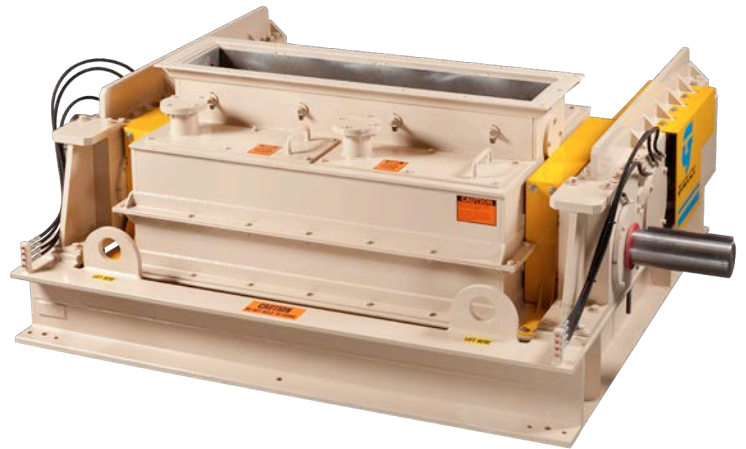

Why Gundlach?

Gundlach is your best resource for reliable performance. Our customers report online service of 98% with our equipment! That level of reliability is the result of the quality construction and high-performance features found in the NANOSIZ-R, such as:

- Rolls constructed of alloyed iron for high surface hardness.
- Heavy-duty steel construction in frame and housing.
- Close-clearance double-row spherical roller bearings with cartridge seals.
- Tightly sealed housing with airflow management ports.
- Roll gap adjustment via a simple hydraulic/mechanical system with accuracy to thousandths of an inch.
- Adjustable side and end liners for close fit to roll elements.
- Flanged input and discharge connections.

WATCH ON  **YouTube**

Check out the cool animation showing how our Gundlach roll crushers are expanding the possibilities of what roll crushers can do

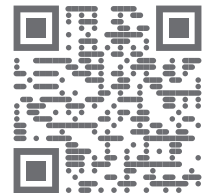

OUR FLAGSHIP BRANDS



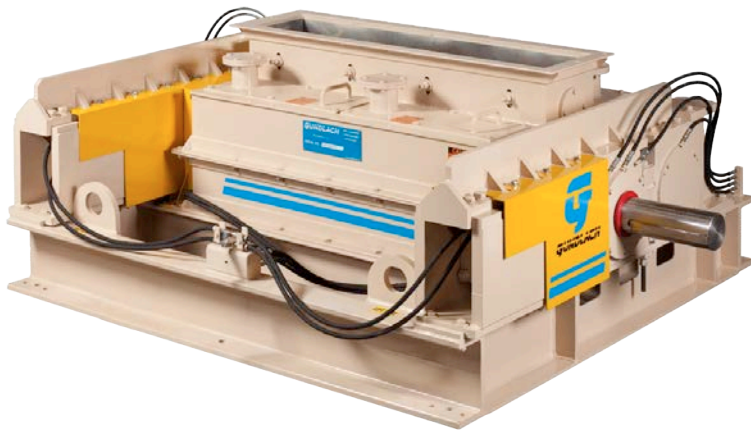

Dimensions and Weights

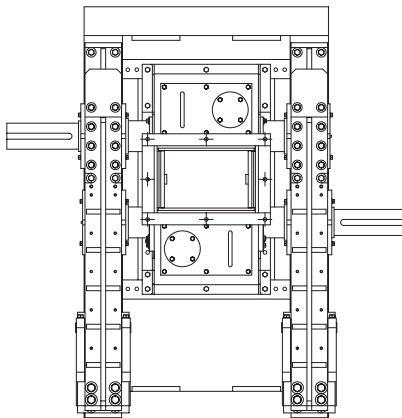

FRONT OF CRUSHER

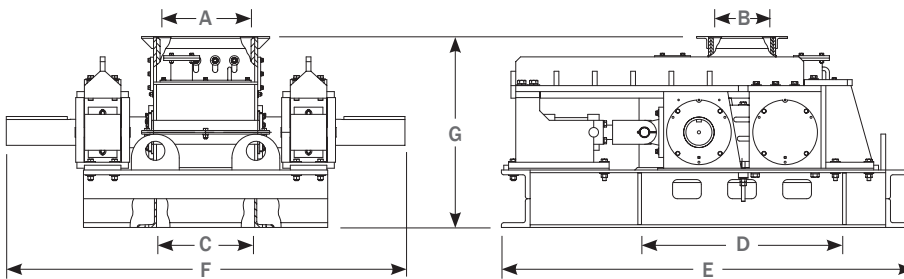
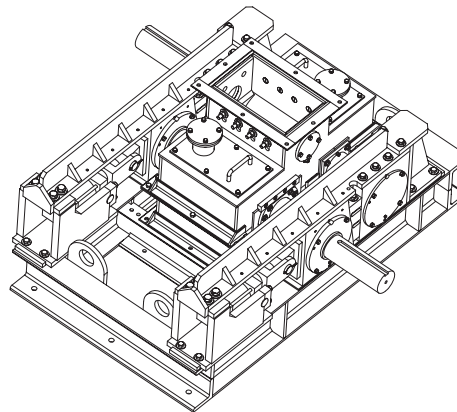

MODEL	MM (IN.) INLET OPENING		DISCHARGE OPENING		APPROXIMATE LAYOUT DIMENSIONS* AND SHIPPING WEIGHTS			WEIGHT KG (LBS.)
	A	B	C	D	LENGTH E	WIDTH F	HEIGHT G	
420S	483 (19)	305 (12)	521 (20-1/2)	1067 (42)	2191 (86-1/4)	2115 (83-1/4)	1016 (40)	4,604 (10,150)
440S	991 (39)	305 (12)	1029 (40-1/2)	1067 (42)	2191 (86-1/4)	2623 (103-1/4)	1016 (40)	8,897 (13,000)
460S	1499 (59)	305 (12)	1537 (60-1/2)	1067 (42)	2191 (86-1/4)	3131 (123-1/4)	1016 (40)	7,121 (15,700)

* Certified drawings will be furnished for installation. Installation supervision is available.

OUR FLAGSHIP BRANDS



www.terrasource.com

Call +1 855-483-7721 or email info@terrasource.com to find the sales representative nearest you.