

*High-performance chip fissuring with
minimum pins and fines generation.*



DYNAYIELD™ II CHIP CONDITIONER

Features/Advantages

Better Uniformity, 98% Uptime

Jeffrey Rader brand DynaYield Chip Conditioners are designed to gently fissure over-thick wood chips to assure proper pulping liquor penetration for optimum cooking and yield, with the least fines and pins generation of any thickness reduction machine.

The DynaYield Chip Conditioner primarily consists of two rolls with specially-designed, textured stainless steel segments providing the surface for conditioning, fissuring, and treating the oversized and over-thick wood chips.

The 90-degree segments are held in place with special Grade-8 fasteners. Removable covers over roll segments allow for easy access for segment maintenance. The two rolls, one fixed and the other dynamic, are each driven by an AGMA Class II shaft-mounted reducer and rotate toward each other. An easily removed drive housing encloses the motor and reducer for safety.

The desired nip setting is obtained by mechanical stops between the fixed roll bearing housing and the

dynamic roll bearing housing. Two independent hydraulic cylinders mounted at the ends of the frame control the dynamic roll movement and applied force.



Low Pins and Fines Generation

With normal oversize wood, the conditioner typically generates less than 1% fines and 2% pins, versus chip slicers generating between 2% to 8% fines and up to 15% pins (based on -3 mm RH fines and -2 mm slot pins).



Reduced Maintenance Costs

Due to reduction in wear parts in contact with material, and due to low speed action of the conditioning process, the wear is significantly less than in other forms of overs processing.

OUR FLAGSHIP BRANDS



Features/Advantages (continued from other side)

Centralized Lubrication

Centralized lubrication stations are included for greasing motors, reducer, bearings, and dynamic roll slide base.

Hydraulic Roll Positioner Power Unit (HPU)

The power unit consists of a flooded suction pumping system with accumulator mounted on a 20 U.S. gallon skid-mounted reservoir.

An air/oil heat exchanger and tank heater provide temperature control in hot and cold ambient environments.

A solenoid valve supplies directional control to the cylinders on the conditioner.

Additional controls provided include high temperature control switch and low fluid level switch. All control enclosures are NEMA 4 to provide all-weather protection.

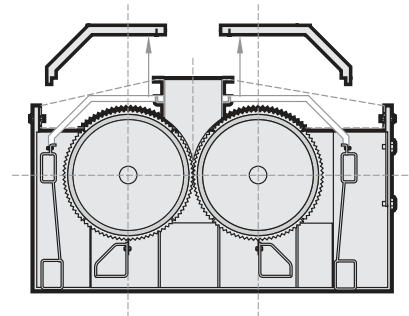

Control Console

A control console operates the DynaYield Chip Conditioner unit and Hydraulic Roll Positioner Power Unit. It is enclosed in a NEMA 4 enclosure, can be remotely mounted, and has the ability to be tied into the customer's PLC.

There is a speed switch on each roll for zero-speed detection. Proximity sensors give indication to operators that nip between rolls is ready for wood processing/operation.

Dimensions and Weights

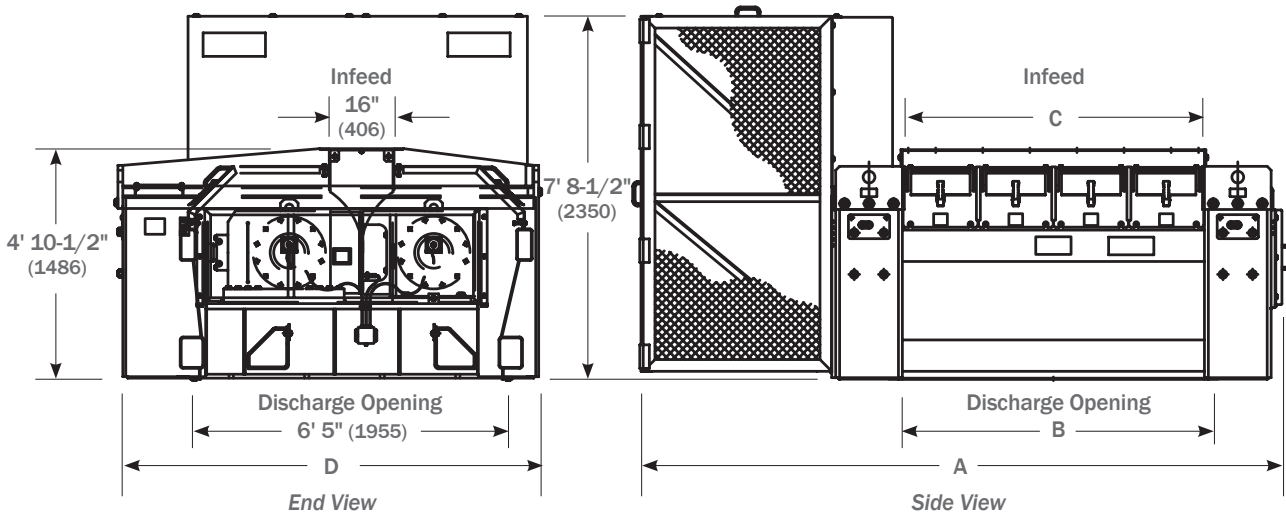

MODEL NO.	MOTORS**	MOTOR REQUIREMENTS, APPROXIMATE LAYOUT DIMENSIONS,* AND SHIPPING WEIGHTS				FT-IN (MM)	
		A	B	C	D	LBS (KG)	
40	2 @ 75 HP, 1 @ 7.5 HP	10' 10-3/4" (3321)	4' 7" (1397)	3' 11" (1194)	8' 3" (2515)	40,000 (18,144)	
60	2 @ 100 HP, 1 @ 7.5 HP	13' 7-3/4" (4159)	6' 7" (2007)	5' 11" (1803)	8' 10" (2692)	54,000 (24,494)	
80	2 @ 150 HP, 1 @ 7.5 HP	15' 11-1/4" (4858)	8' 5" (2565)	7' 10" (2388)	9' 1-5/8" (2784)	65,000 (29,484)	

*Certified drawings will be furnished for installation. Installation supervision is available. **1800 RPM electric motors as indicated to be supplied by customer. (HPU comes equipped with one 1.5 kW NEMA 4 heater.)

OUR FLAGSHIP BRANDS

